

100
ATLAS 1919 - 2019

ATLAS
SINCE 1919

**STABLE.
STRONG.
STEADY.**

-  26.1 - 27.4 t
-  129 kW (175 hp)
-  10.3 - 16.4 m



MATERIAL HANDLING MACHINE 270MH

WWW.ATLASGMBH.COM

TECHNICAL SPECIFICATION 270MH

Technical specifications

ENGINE		
Power according to ISO 9249.....129 kW (175 hp)	Cylinder capacity.....6700 cm ³	Air filter.....Dry air filter
RPM1800/min	Number of cylinders.....6	Battery.....2 x 12 V / 100 Ah
Make.....CUMMINS QSB 6.7 (Tier 4F)	Borehole/lift.....101 / 126	Alternator.....24 V / 70 Ah
DesignTurbocharger / intercooler	Cooling system.....Water-cooled	Starter.....24 V / 3,2 kW

HYDRAULIC SYSTEM		
<ul style="list-style-type: none"> • Load limit controlled high-performance piston pump • 7 standard consumer loads in one control block • Sensitive, proportional, independent control • Primary and secondary protection against overload 	<ul style="list-style-type: none"> • Load-retaining and fine lowering valve in lifting circuit • Pump flow control • Grab and grab-rotating function • Fuel-efficient flow-on-demand control • Pipe-break protection valves for lifting cylinders 	<ul style="list-style-type: none"> • Up to 2 additional control circuits possible • Max. oil flow.....380 l/min • Max. operating pressure.....340 bar • Operating modes:: 3 pre-programmed modes (Fine, Eco, Power)

SWING ASSEMBLY		
• Swing motor:	Axial piston motor with priority valve	• Max. swing speed11/min
• Swing gear	Planetary transmission	• Swing torque63.2 kNm
• Swing brake:	Automatic multidisc brake	

TRACTION		
• Variable displacement motor	• Maximum speed20 km/h	• Tractive force132.8 kN
• Power-shift transmission	• Terrain speed5 km/h	• Max. gradeability55%
• Double-acting brake valve	• Crawling speed1 km/h	• Dual circuit brake systemMulti-disc
• Driving direction pre-selection via switch in joystick		• Parking brakeMulti-disc

UNDERCARRIAGE		
• 40 t special excavator axles	• Steering axle with automatic oscillating axle blocking	• 8 tyres16 PR 10.00 - 20

FILL CAPACITIES		
• Fuel tank 382 Liter	• Engine oil 20 Liter	• Hydraulics system400 Liter
• Cooling system 42 Liter	• Hydraulic tank 224 Liter	• AdBlue® tank..... 18.9 Liter

DRIVER'S CAB		
<ul style="list-style-type: none"> • Meets latest safety standards • Extra large entry zone • Spacious leg room • Excellent circumferential visibility • Preparation for radio installation with mute function 	<p>CONTROL:</p> <ul style="list-style-type: none"> • Ergonomic joystick • Slim steering column, height and tilt adjustable • Indicators, controls and operating switches are clearly arranged 	<p>CLIMATE CONTROL:</p> <ul style="list-style-type: none"> • Air conditioning equipped as standard • Very good air distribution through optimally arranged nozzles
<p>DRIVER'S SEAT:</p> <ul style="list-style-type: none"> • Air-cushioned comfort seat (optional seat heating) • Arm rests and lumbar support • Seat adjustable separately from console 	<p>MONITORING</p> <ul style="list-style-type: none"> • Operating data display screen • Automatic system for monitoring, warning and storage of data 	<p>SOUND LEVELS:</p> <ul style="list-style-type: none"> • ISO6396 (L_pA) in driver's cab74 dB(A) • 2000/14EG (L_wA) ambience level101 dB(A)

WORKING EQUIPMENT 270MH

Working equipment

OPERATING WEIGHTS

	LOADING BOOM 6.60 m (C25.5i)	LOADING BOOM 8.00 m (C25.6i)	LOADING BOOM 8.00 m (C25.6i)
	Stick 5.00 m (D25.15i)	Stick 6.00 m (D25.16i)	Stick 6.00 m (D25.16is)
4 outriggers	26.5 t	27.0 t	27.4 t

Operating weight with driver, solid rubber tyres, completely filled implement and 1.0 t for attachments and 1.4 t for lift-cab (option).

EQUIPMENT

BASIC DEVICE Atlas 270MH	Standard equipment	
<ul style="list-style-type: none"> 270MH material handler with quadruple outrigger support and 2 lifting cylinders (A22.39) 	Engine: <ul style="list-style-type: none"> Automatic idle Diesel pre-filter Engine monitoring 	<ul style="list-style-type: none"> Slim steering column, height and tilt adjustable Different options for storage, compartment for documents Ready for electric cooling box Seat adjustable separately from console Heat-absorbing glass, tinted windows Automotive drive and cruise control Operating data screen display Bottle holder
Mono Booms: <ul style="list-style-type: none"> Loading boom 6.60 m (C25.5i) Loading boom 8.00 m (C25.6i) 	Hydraulics: <ul style="list-style-type: none"> Grab and grab-rotating function Accumulator for emergency lowering of the arm system Pipe break protection valves for lifting cylinders Overload warning device Cylinder end damping Max. load-limit control 	Equipment: <ul style="list-style-type: none"> Combined lubricating points for swing bearing and arm equipment
Mono Sticks: <ul style="list-style-type: none"> Stick 5.00 m (D25.15i) Stick 6.00 m (D25.16i) Stick 6.00 m (D25.16is) 	Cab: <ul style="list-style-type: none"> Automatic air-conditioning Preparation for radio installation with mute function 	Undercarriage: <ul style="list-style-type: none"> Power-shift transmission Wet disc brakes Tool box in the undercarriage

ADDITIONAL EQUIPMENT

Engine: <ul style="list-style-type: none"> Refueling pump Engine speed adjustment via potentiometer Auxiliary heating Cold start assistance 	Equipment: <ul style="list-style-type: none"> Automatically controlled and monitored electric central lubrication system 	<ul style="list-style-type: none"> Cab elevation 1.2 m/0.6 m Lift-Cab (elevation up to 2.5m) Xenon working lights
Hydraulics: <ul style="list-style-type: none"> Hydr. adaptor kit, switch supports pairwise in front and back Hydr. adaptor kit, switch supports individually Bio oil 	Cab: <ul style="list-style-type: none"> Cab protection guard Beacon light Heated driver's seat GPS/GSM telemetric system for monitoring of operating data, consumption, position Radio CD/MP3, front AUX in, USB Thermoelectric cooling box 	Undercarriage: <ul style="list-style-type: none"> Solid rubber tyres
Other special equipment: see price list		

ATTACHMENTS



Load hook

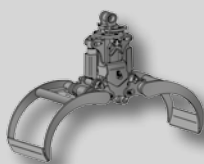

Log grab

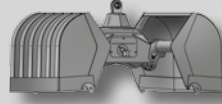

Clamshell grab

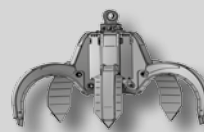

Orange peel grab

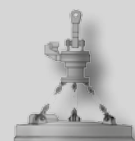

Load lifting magnet





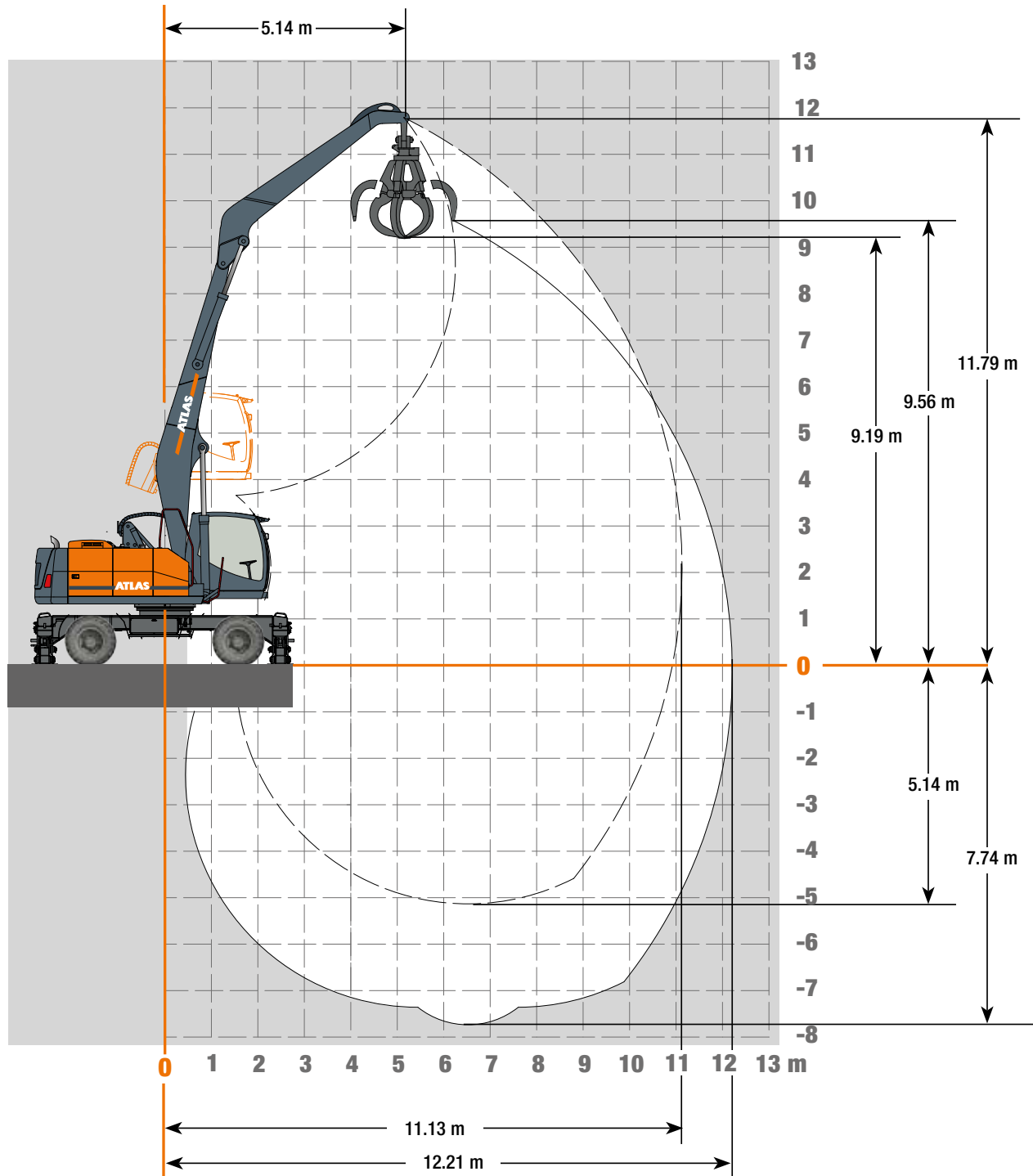



















WORKING RANGES 270MH

Working ranges Loading boom 6.60 m (C25.5i) and stick 5.00 m (D25.15i)



LIFTING CAPACITIES 270MH

Lifting Capacities Loading boom 6.60 m (C25.5i) and stick 5.00 m (D25.15i)

Lifting Capacities Loading boom 6.60 m (C25.5i) with stick 5.00 m (D25.15i). Max. reach 12.21 m										
HEIGHT	Undercarriage type		4.0 m	5.0 m	6.0 m	7.0 m	8.0 m	9.0 m	10.0 m	11.0 m
+12.0 m	FRONT 	SDB supported		10806						
		SDB raised		10579*						
	LATERAL 	SDB supported		10806						
		SDB raised		7203*						
+10.5 m	FRONT 	SDB supported			8880	8448				
		SDB raised			8179*	6286*				
	LATERAL 	SDB supported			8880	8354*				
		SDB raised			5651*	4355*				
+ 9.0 m	FRONT 	SDB supported				8059	7694	7404		
		SDB raised				6415*	5110*	4132*		
	LATERAL 	SDB supported				8059	6767*	5505*		
		SDB raised				4473*	3548*	2834*		
+ 7.5 m	FRONT 	SDB supported				8119	7667	7270	6464*	
		SDB raised				6401*	5122*	4187*	3456*	
	LATERAL 	SDB supported				8119	6780*	5562*	4628*	
		SDB raised				4459*	3560*	2885*	2344*	
+ 6.0 m	FRONT 	SDB supported			9247	8518	7907	7382	6469*	
		SDB raised			8078*	6275*	5044*	4147*	3461*	
	LATERAL 	SDB supported			9247	8343*	6697*	5521*	4633*	
		SDB raised			5561*	4345*	3487*	2848*	2348*	
+ 4.5 m	FRONT 	SDB supported		11691	10245	9163	8315	7604*	6411*	5491*
		SDB raised		10452*	7749*	6057*	4898*	4054*	3409*	2895*
	LATERAL 	SDB supported		11691	10245	8109*	6543*	5422*	4579*	3915*
		SDB raised		6971*	5267*	4146*	3353*	2761*	2299*	1925*
+ 3.0 m	FRONT 	SDB supported	17042	13576	11397	9887	8763	7464*	6324*	5448*
		SDB raised	14135*	9745*	7320*	5780*	4713*	3931*	3331*	2856*
	LATERAL 	SDB supported	17042	13575*	9991*	7812*	6347*	5293*	4497*	3875*
		SDB raised	8793*	6360*	4885*	3894*	3183*	2646*	2226*	1888*
+ 1.5 m	FRONT 	SDB supported	8961	15001	12290	10441	8796*	7321*	6232*	5407*
		SDB raised	8961	9057*	6896*	5502*	4526*	3804*	3249*	2819*
	LATERAL 	SDB supported	8961	12807*	9529*	7515*	6149*	5160*	4412*	3836*
		SDB raised	7777*	5766*	4508*	3642*	3010*	2523*	2149*	1853*
+ 0 m	FRONT 	SDB supported	6390	15294	12533	10574	8622*	7211*	6173*	5384*
		SDB raised	6390	8598*	6581*	5284*	4376*	3708*	3196*	2797*
	LATERAL 	SDB supported	6390	12294*	9186*	7281*	5991*	5059*	4357*	3814*
		SDB raised	6390	5370*	4227*	3444*	2872*	2438*	2099*	1833*
- 1.5 m	FRONT 	SDB supported	7826	14404	11977	10136	8539*	7161*	6153*	
		SDB raised	7826	8440*	6444*	5180*	4305*	3664*	3178*	
	LATERAL 	SDB supported	7826	12118*	9037*	7171*	5915*	5013*	4338*	
		SDB raised	7134*	5234*	4105*	3349*	2806*	2397*	2082*	
- 3.0 m	FRONT 	SDB supported	10205	12418	10534	8969	7622	6371	4986	
		SDB raised	10205	8458*	6436*	5170*	4303*	3677*	3216*	
	LATERAL 	SDB supported	10205	12138*	9029*	7159*	5913*	5026*	4377*	
		SDB raised	7211*	5249*	4098*	3340*	2804*	2409*	2118*	
- 4.5 m	FRONT 	SDB supported		9354	8104	6888	5658			
		SDB raised		8605*	6536*	5249*	4380*			
	LATERAL 	SDB supported		9354	8104	6888	5658			
		SDB raised		5376*	4186*	3412*	2875*			

The specified max. loading capacities in kilogrammes (kg) include a stability of 25% or are calculated at 87% of the hydraulic lifting power, as per ISO10567. These values are applicable at the tip of the arm with optimum positioning of the corresponding arm system. Weights of attached load carrying accessories (grab, magnet, load hook, etc.) are not included with the load carrying values. *Value limited due to excavator stability.





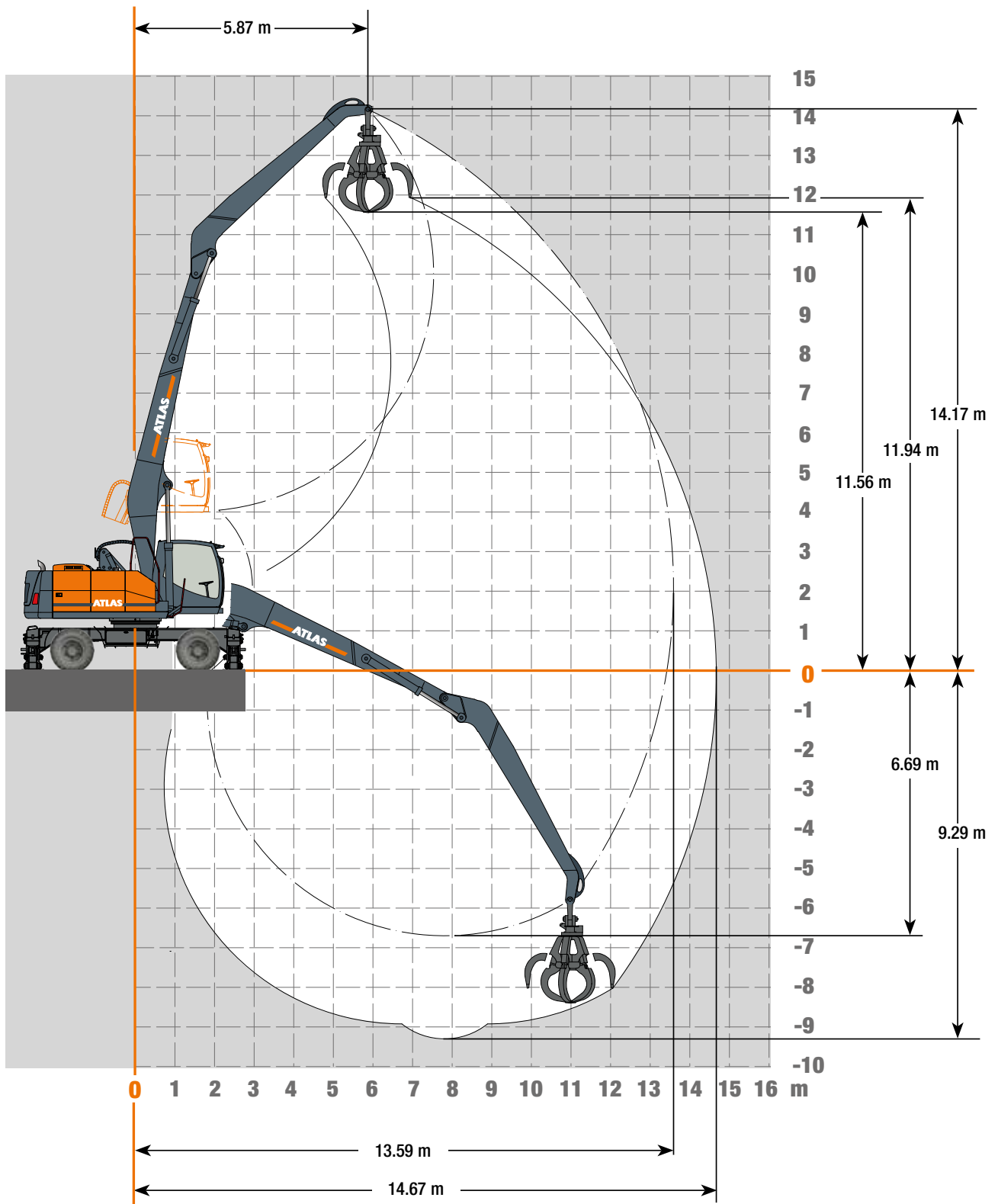



































WORKING RANGES 270MH

Working ranges Loading boom 8.00 m (C25.6i) and stick 6.00 m (D25.16i)



LIFTING CAPACITIES 270MH

Lifting Capacities Loading boom 8.00 m (C25.6i) and stick 6.00 m (D25.16i)

Lifting Capacities Loading Boom 8.00 m (C25.6i) with stick 6.00 m (D25.16i). Max reach 14.67 m													
HEIGHT	Undercarriage type		4.5 m	5.5 m	6.5 m	7.5 m	8.5 m	9.5 m	10.5 m	11.5 m	12.5 m	13.5 m	
+14.5 m	FRONT		SDB supported										
	LATERAL		SDB raised										
+14.0 m	FRONT				8002								
	LATERAL				7108*								
+13.5 m	FRONT				8002	7959	7242						
	LATERAL				4888*	7274*	5632*						
+12.0 m	FRONT				7959	6925	6592	6193					
	LATERAL				5038*	5916*	4737*	3822*					
+10.5 m	FRONT				6925	6376	6086	5844					
	LATERAL				4111*	4844*	3963*	3262*					
+9.0 m	FRONT				6376	6376*	5250*	4370*					
	LATERAL				4216*	3385*	2751*	2249*					
+7.5 m	FRONT				6376*	6376*	5271*	4421*	5232*	4519*			
	LATERAL				4216*	3385*	2751*	2249*	1831*	2763*	2334*	4519*	
+6.0 m	FRONT				7027	6565	6165	5813	5238*	4519*			
	LATERAL				4110*	3309*	2702*	2225*	1836*	1503*			
+4.5 m	FRONT				8219	7484	6884	6381	5948	5190*	4506*		
	LATERAL				4951*	3914*	3165*	2599*	2154*	1794*	1493*		
+3.0 m	FRONT		10231	10442	9083	8073	7287	6654	5916*	5108*	4458*	3919*	
	LATERAL		10231	8844*	6750*	5372*	4395*	3667*	3102*	2650*	2278*	1962*	
+1.5 m	FRONT		10231	10442	9083	7214*	5903*	4941*	4204*	3619*	3143*	2742*	
	LATERAL		8060*	5913*	4566*	3642*	2969*	2456*	2052*	1724*	1451*	1215*	
+0 m	FRONT		14671	11831	9980	8671	7691	6756*	5776*	5010*	4394*	3890*	
	LATERAL		11036*	8053*	6244*	5027*	4152*	3492*	2976*	2561*	2219*	1935*	
-1.5 m	FRONT		14671	11204*	8560*	6848*	5647*	4758*	4072*	3527*	3082*	2714*	
	LATERAL		6910*	5218*	4109*	3326*	2743*	2292*	1933*	1639*	1394*	1189*	
-3.0 m	FRONT		5183	12812	10644	9120	7783*	6562*	5637*	4911*	4329*	3859*	
	LATERAL		5183	7318*	5761*	4693*	3914*	3319*	2850*	2471*	2160*	1906*	
-4.5 m	FRONT		5183	10395*	8039*	6492*	5396*	4577*	3941*	3433*	3021*	2685*	
	LATERAL		5183	4573*	3674*	3020*	2522*	2130*	1814*	1554*	1338*	1161*	
-6.0 m	FRONT		3946	10181	10852	9155*	7555*	6396*	5517*	4832*	4283*	3839*	
	LATERAL		3946	6814*	5395*	4425*	3715*	3172*	2743*	2399*	2117*	1888*	
-7.5 m	FRONT		3946	9840*	7644*	6207*	5186*	4422*	3829*	3359*	2977*	2666*	
	LATERAL		3946	4130*	3345*	2774*	2338*	1992*	1713*	1485*	1297*	1144*	
-9.0 m	FRONT		4846	9078	10541	8963*	7410*	6291*	5445*	4785*	4260*		
	LATERAL		4846	6587*	5194*	4261*	3589*	3078*	2678*	2356*	2096*		
-10.5 m	FRONT		4846	9078	7428*	6033*	5053*	4325*	3761*	3314*	2955*		
	LATERAL		4846	3930*	3163*	2625*	2221*	1905*	1651*	1445*	1277*		
-12.0 m	FRONT		6332	9925	9704	8416	7348	6246*	5418*	4776*	4239*	3997	
	LATERAL		6332	6538*	5128*	4198*	3535*	3038*	2653*	2348*	2110*	1906*	
-13.5 m	FRONT		6332	9537*	7357*	5965*	4997*	4283*	3736*	3306*	2969*		
	LATERAL		5146*	3887*	3104*	2566*	2171*	1868*	1628*	1437*	1290*		
-14.5 m	FRONT		8074	9495	8337	7310	6394	5556	4745	4082			
	LATERAL		8074	6608*	5160*	4214*	3547*	3053*	2677*	2388*			
-15.5 m	FRONT		8074	9495	7392*	5982*	5009*	4298*	3760*	3347*			
	LATERAL		5269*	3949*	3134*	2581*	2182*	1882*	1650*	1475*			
-16.5 m	FRONT				7107	6395	5659	4912	4132	3234			
	LATERAL				4094*	3239*	2664*	2255*	1954*	1734*			

The specified max. loading capacities in kilogrammes (kg) include a stability of 25% or are calculated at 87% of the hydraulic lifting power, as per ISO10567. These values are applicable at the tip of the arm with optimum positioning of the corresponding arm system. Weights of attached load carrying accessories (grab, magnet, load hook, etc.) are not included with the load carrying values. *Value limited due to excavator stability.





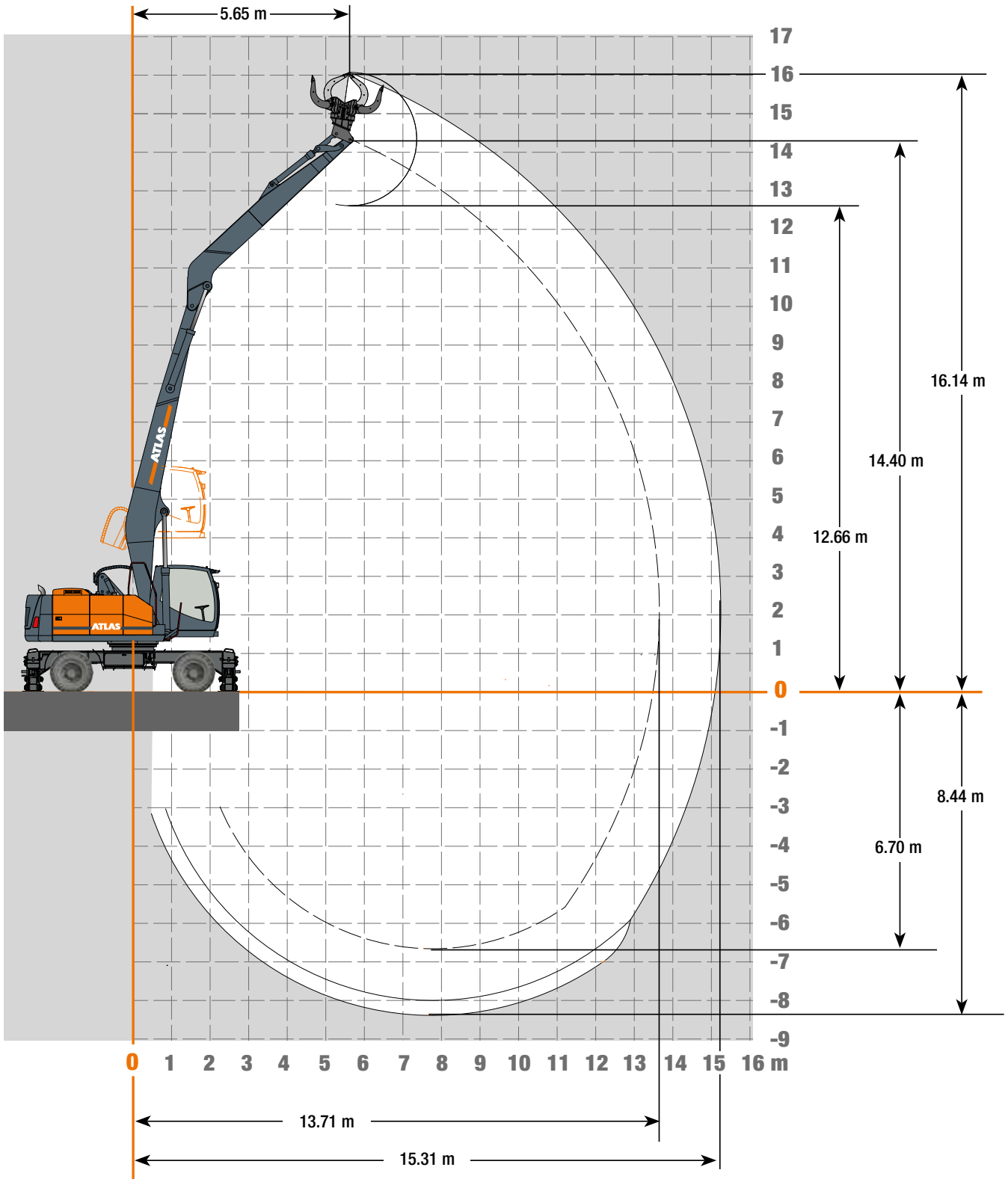



























WORKING RANGES 270MH

Working ranges Loading boom 8.00 m (C25.6i) and stick 6.00 m (D25.16is)



LIFTING CAPACITIES 270MH

Lifting Capacities Loading boom 8.00 m (C25.6i) and stick 6.00 m (D25.16is)

Lifting Capacities Loading Boom 8.00 m (C25.6i) with stick 6.00 m (D25.16is). Max reach 15.31 m												
HEIGHT	Undercarriage type		4.5 m	5.5 m	6.5 m	7.5 m	8.5 m	9.5 m	10.5 m	11.5 m	12.5 m	13.5 m
+14.5 m	FRONT		SDB supported									
	LATERAL		SDB raised									
+14.0 m	FRONT				8091							
	LATERAL				7117*	8091						
+13.5 m	FRONT				7981	7331						
	LATERAL				7276*	7331						
+12.0 m	FRONT					6947	6624	6283				
	LATERAL					5920*	4752*	3847*				
+10.5 m	FRONT						6403	6121	5886			
	LATERAL						4854*	3981*	3288*			
+9.0 m	FRONT					6780	6410	6087	5800	5257*		
	LATERAL					5999*	4854*	4000*	3335*	2792*		
+7.5 m	FRONT					7049	6595	6201	5854	5263*	4548*	
	LATERAL					5888*	4775*	3949*	3310*	2797*	2367*	
+6.0 m	FRONT				8244	7517	6922	6422	5992	5216*	4536*	
	LATERAL				7183*	5683*	4628*	3844*	3239*	2755*	2356*	
+4.5 m	FRONT		10313	10483	9127	8119	7335	6702	5945*	5138*	4490*	3952*
	LATERAL		10313	8861*	6774*	5399*	4425*	3698*	3135*	2684*	2313*	1998*
+3.0 m	FRONT		14761	11907	10047	8734	7750	6791*	5811*	5044*	4428*	3924*
	LATERAL		11102*	8105*	6289*	5069*	4192*	3531*	3014*	2598*	2257*	1973*
+1.5 m	FRONT		5264	12920	10734	9199	7830*	6605*	5677*	4950*	4367*	3895*
	LATERAL		5264	7402*	5827*	4750*	3964*	3365*	2893*	2512*	2200*	1945*
+ 0 m	FRONT		4032	10258	10959	9222*	7612*	6446*	5563*	4874*	4323*	3876*
	LATERAL		4032	6920*	5477*	4493*	3774*	3224*	2791*	2444*	2160*	1928*
-1.5 m	FRONT		4931	9158	10657	9039*	7474*	6346*	5495*	4830*	4301*	
	LATERAL		4931	6704*	5286*	4337*	3654*	3136*	2729*	2403*	2140*	
-3.0 m	FRONT		6417	10006	9825	8520	7416*	6304*	5469*	4822*	4059	
	LATERAL		6417	6659*	5224*	4277*	3603*	3098*	2706*	2396*	2153*	
-4.5 m	FRONT		8158	9638	8458	7414	6486	5638	4818	3928		
	LATERAL		8158	6728*	5256*	4294*	3615*	3113*	2729*	2435*		
-6.0 m	FRONT			7244	6512	5759	5001	4211	3303			
	LATERAL			6887*	5369*	4381*	3691*	3188*	2815*			

The specified max. loading capacities in kilogrammes (kg) include a stability of 25% or are calculated at 87% of the hydraulic lifting power, as per ISO10567. These values are applicable at the tip of the arm with optimum positioning of the corresponding arm system. Weights of attached load carrying accessories (grab, magnet, load hook, etc.) are not included with the load carrying values. *Value limited due to excavator stability.

DIMENSION 270MH

Dimensions [m]

Standard-Cab

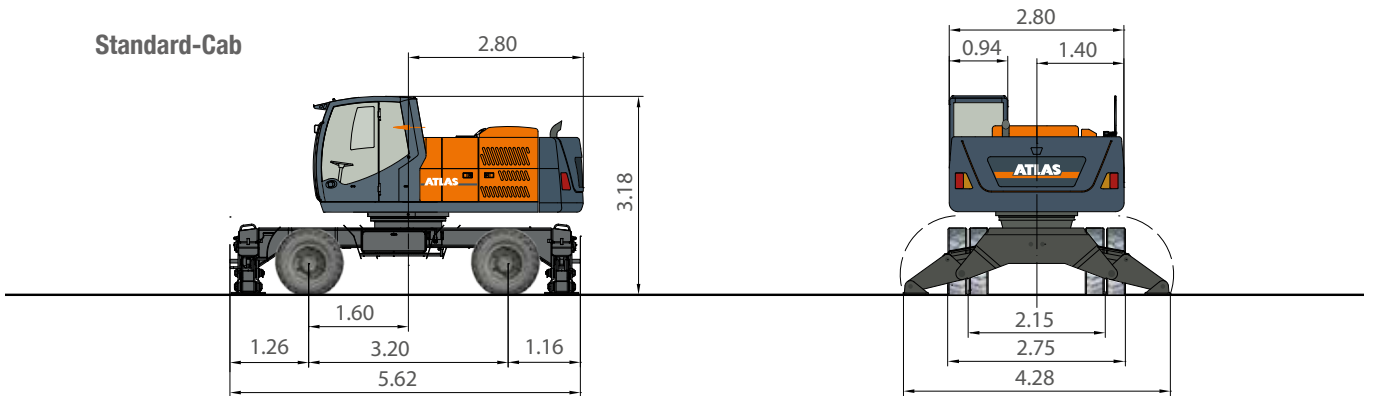

Lift-Cab

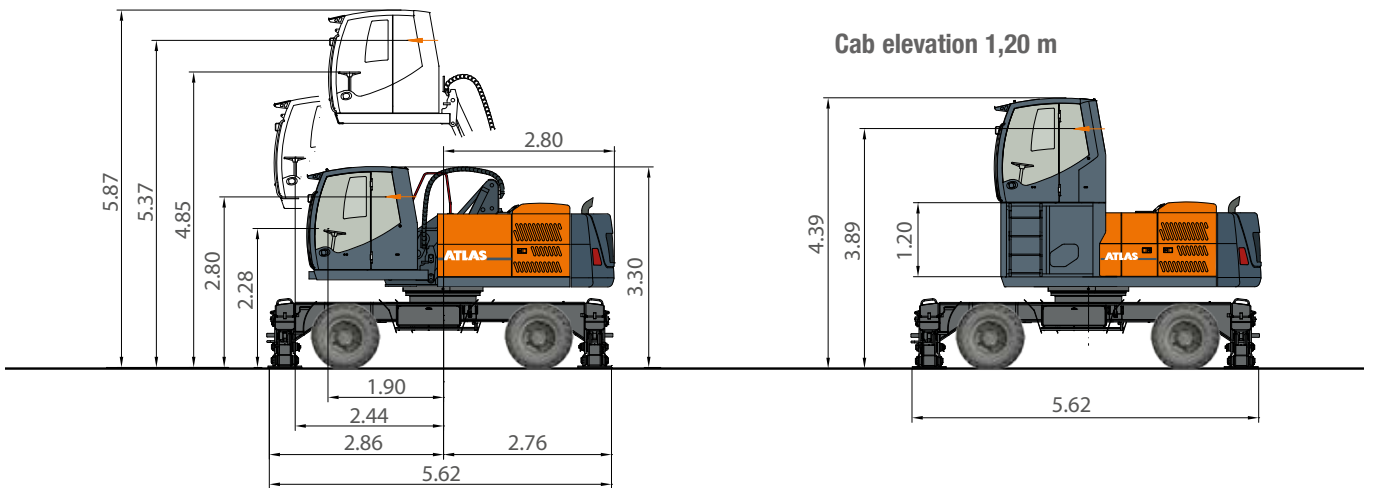

A TRANSPORT HEIGHT

- Loading boom 6.60 m (C25.5i) with stick 5.00 m (D25.15i)3.41 m
- Loading boom 8.00 m (C25.6i) with stick 6.00 m (D25.16i)3.30 m
- Loading boom 8.00 m (C25.6i) with stick 5.00 m (D25.15i)3.30 m

B TRANSPORT LENGTH

- Loading boom 6.60 m (C25.5i) with stick 5.00 m (D25.15i)9.81 m
- Loading boom 8.00 m (C25.6i) with stick 6.00 m (D25.16i)11.26 m
- Loading boom 8.00 m (C25.6i) with stick 5.00 m (D25.15i)11.26 m

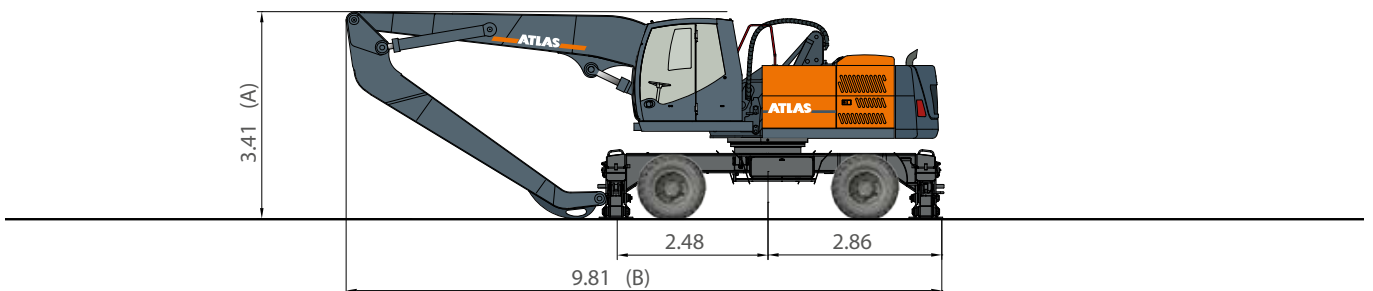

Further variations of cabs on request

GANDERKESEE FACTORY

Atlas GmbH
Atlasstraße 6
D-27777 Ganderkesee,
Germany

Tel.: +49 (0) 4222 954 0
Fax: +49 (0) 4222 954 220
E-mail: info@atlasgmbh.com
www.atlasgmbh.com



VECHTA FACTORY

Atlas GmbH
Theodor-Heuss-Str. 3
D-49377 Vechta
Germany

T: +49 (0) 4441 954 0
F: +49 (0) 4441 954 299
E-mail: info@atlasgmbh.com
www.atlasgmbh.com



DELMENHORST FACTORY

Atlas GmbH
Stedinger Straße 324
D-27751 Delmenhorst
Germany

T: +49 (0) 4221 49 10
F: +49 (0) 4221 49 14 43
E-mail: info@atlasgmbh.com
www.atlasgmbh.com

ATLAS CRANES UK LTD NATIONAL SALES & SERVICE FACILITY

Wharfedale Road,
Euroway Trading Est.
Bradford, England BD4 6SL
United Kingdom

T: +44 8444 99 66 88
F: +44 1274 65 37 85
E-mail: atlasuk@atlasgmbh.com
www.atlas-cranes.co.uk
www.atlasgmbh.com



SINCE 1919
ATLAS



www.atlasgmbh.com

ATLAS GmbH
EXCAVATORS
Atlasstraße 6
D-27777 Ganderkesee, Germany
T: +49 (0) 4222 954 0
Fax: +49 (0) 4222 954 220
info@atlasgmbh.com