

AERIAL PLATFORM MAINTENANCE SOLUTION



SMART USE "FAST AND EASY" THE VT 75 HYBRID OFFERS COULD BE USED AS A SELF-PROPELLED AERIAL WORK PLATFORM THAT ALLOWS USE WITH A MOVING VEHICLE UP TO A SPEED OF 5 KM/H WITHOUT THE NEED FOR STABILIZATION



VT ELECTRIC LINE MAINTENANCE THIS VERSION HAS BEEN STUDIED TO SATISFY THE NECESSITY OF MAINTENANCE IN AN URBAN ENVIRONMENT. LIGHTING, TRAFFIC LIGHTS, ELECTRIC LINES FOR TRAMS ETC.



VT TUNNEL MAINTENANCE THIS VERSION IS EQUIPPED WITH A LARGE ALUMINIUM AND STEEL BASKET WITH A LARGE LOAD CAPACITY. THE IDEAL MACHINE FOR THE MAINTENANCE OF MOTORWAY TUNNELS



VT WAGON. THIS VERSION MOUNTED ON RAILWAY TROLLEY OR MULTIPURPOSE VEHICLE IS IDEAL FOR ALL MAINTENANCE NEEDS OF RAILWAY LINES OR SUBWAY



COMPACT DIMENSIONS THE IDEAL SOLUTION FOR WORKING IN SMALL SPACES AS HISTORIC CITY CENTERS, TUNNERS



JOYSTICK AND INFORMATION DISPLAY WITH DIAGNOSTIC FUNCTION



WIRELESS REMOTE CONNECTION



ECO-VERSION. DUAL POWER SUPPLY, IDEAL FOR USE IN CLOSED ENVIRONMENTS. AUTONOMY OF 5/6 WORKING HOURS, AUTOMATIC RE-CHARGE WITH TRUCK ENGINE OR WITH 220V POWER SOURCE

VT HYBRID AERIAL PLATFORM MAINTENANCE SOLUTION



- ▶ VT 75 is assembled on truck without stabilizers (7,5 working height)
- ▶ VT 9 is assembled with 4 hydraulic stabilizers (9m working height)
- ▶ VT 75 configuration is made up of 1 high quality steel articulated arm, without tube-holder channels external to the arm, which can be easily inspected in case of need; machine column fixed to the subframe
- ▶ VT 9 is equipped with a telescopic arm
- ▶ Rotation of the nacelle through hydraulic actuator
- ▶ Operation of the VT 75 a 24 V electric pump, hydraulic pump, pressure gauge at the hydraulic system, steel oil tank with filter and level indicator and hydraulic system protection system with maximum pressure valve
- ▶ The VT electric line maintenance range is equipped with insulated basket tested up 6 kV and certified 1.5 kV The VT electric line maintenance range is equipped with dual power supply, ideal for use in closed environments: by battery pack and electric pump or alternatively via a hydraulic pump connected to the motor of the vehicle
- ▶ The VT 75 can be used with the vehicle in motion up to a speed of 5 Km/h



7,5-9 m



6-7 m



450 Kg



Wireless connection



180° +180°



1,5 Kw



Whitout stabilizers



Radio controls



Ground control unit



3/5°



Hybrid

WORK DIAGRAM

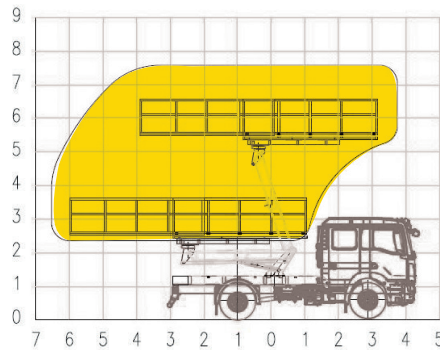
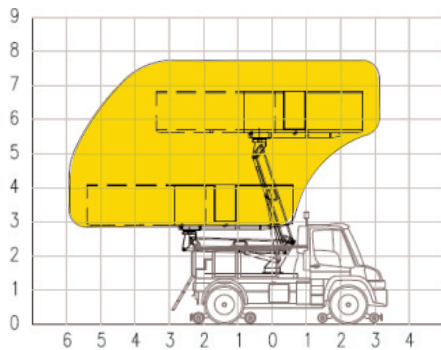

CAGE ROTATION

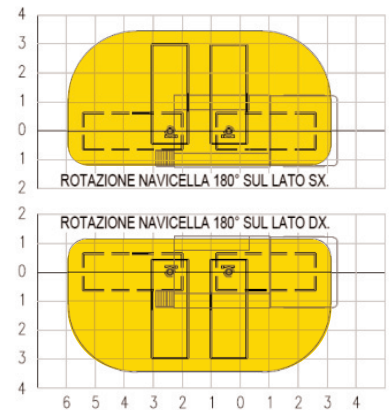

CAGE CONTROL STATION



3.5" FUNCTION DISPLAY

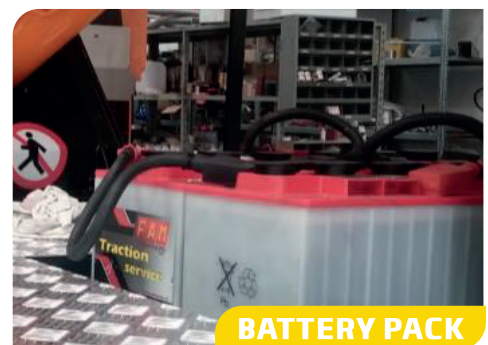

BATTERY PACK

DISTRIBUTOR



NOTES

Technical information is subject to change without prior notice. Images may show optional equipment. Installations and /or options may not be available in your specific region.

* Depending on the vehicle.

** Max payload with a driver, a passenger and a full tank of fuel (220 Kg added to the installation weight).